

IQ:250XR

INTELLIGENT ANPR PERFORMANCE

MAV[™]
ANPR TECHNOLOGY FOR
INTELLIGENT TRAFFIC SOLUTIONS

4G All-In-One Dual HD Zoom Camera

Incorporating HD image quality, motorized zoom, high speed ANPR recognition and maxIRange™ pulsed IR lighting in one efficient unit, the IQ:250XR range sets new standards for intelligent ANPR cameras.



HD Video

Up to 8m lane width capability from digital video for maximum quality



Integrated ANPR Engine

To provide high accuracy reads with meta data



JSON Web Services

Simple integration into applications using open interface



Zoom Cameras

10 × Optical controllable truEZoom™ for the perfect field of view



Powerful Pulsed IR +

maxiRange™ for true day/night number plate recognition



Range

10M to 40M options for wide or Narrow IR



Easy Installation

Full setup using web browser with live video



Stand-alone

1P68 with optional sunshields and brackets for quick installation



4G Router

3G/4G Router with access to external sim slot



Office Data Management

Store and forward for offline data transfer (Optional)

IQ:250XR

INTELLIGENT ANPR PERFORMANCE

Intelligence to Capture 3 Lanes



Intelligent ANPR

The IQ:250XR provides recognition up to 8m lane width for detection of plates and is simple to set up with truEZoom™ for perfect field of view at distances from 6m up to 40m. Improved low light image. Setup is performed using the camera's API or from any browser using the IQX range's web setup with live video feed.

By performing the ANPR recognition within the camera network traffic is massively reduced. Real time recognition is performed on raw high definition images at full frame rate and will work for all traffic speeds from high speed highway gantry systems to access control.

The IQX range incorporates high grade processing within the unit to give industry leading ANPR accuracy. Extensive metadata is provided for each plate read to offer application developers everything needed to determine plate characteristics, direction of travel and provide cropped overview and plate patch images. All this is available from the internal server using open standard JSON web services.

The Internal data management of the IQX range enables store and forward whilst offline, ensuring no data is lost. The IQ:250XR offers integrated 4G router and store and forward buffering to provide up to one million cached reads or immediate data transfer via an API supporting JSON, FTP, UTMCI.2 and Web Services. The IQ:250XR is hermetically sealed to IP68 and can be powered using PoE+ to give a single cable install.



IQ:250XR

ALL-IN-ONE ANPR HD ZOOM CAMERA WITH INTEGRAL ANPR RECOGNITION

Technical Data

SPECIFICATIONS

Recognition Range	Capture of up to 8m of traffic lanes from 6m to 40m based on 850nm IR on EU retro-reflective plates
Motorised Zoom	Controllable 54° to 4° Horizontal Field of View Lens equivalent 5.1mm to 51mm
Shutter / Iris	1/50 to 1/10,000 / F1.4 (wide) to F4.2 (tele)
Image (ANPR and Overview)	Two HD cameras: 1280(H) x 720(V) effective pixels digitally connected to ANPR processor at 25 fps
IR illumination	4 pulsed LED arrays with lenses (850nm standard, White light, 740nm optional)
Low Light	ANPR: 0.0 Lux with IR illumination OV: 0.05 Lux (Colour/B&W (no IR Cut) selectable)
Optical Filters	IR: Bandpass matched to LEDs OV: Day/Night IR Cut Filter
Camera Control	Integrated web server provides full camera and illuminator setup pages and live preview from any connected browser (no plug-ins required)

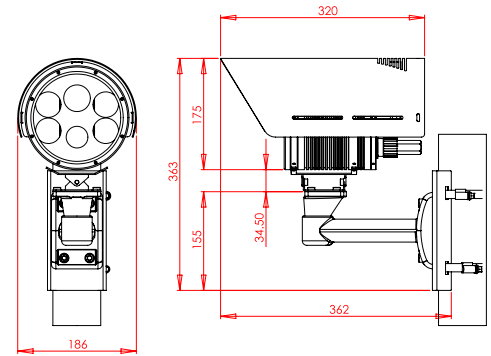

ANPR ENGINE FUNCTIONALITY

ANPR Processor	Dual Core DSP with co-processor and two channel internal parallel video input
ANPR Software / Presets	ANPR license and configuration upload via web based configuration pages for simple remote management
ANPR Engine Protocol	JSON web services provide full access to overview and plate patch images and metadata as push or pull messages for easy integration into applications (O/S independent) and via web pages
ANPR Metadata	Multiple plate tracking with IDs, full availability of plate movement/size data through field of view
ANPR Features	Image cropping options for Overview image, advanced de-skew and yaw correction, character spacing validation, country of origin matching, lane determination, direction of travel, plate tracking and geometry

PHYSICAL SPECIFICATIONS

Operating Voltage	10 – 15 VDC protected or PoE+ (802.3at)
Network Connections	10/100 Base-T physical
Power Consumption	Nominally 14W
Size (WxHxD)	163 x 163 x 145mm (cylindrical) excluding connectors, mount and sunshield
Weight	2.5kg excluding mount and sunshield
Enclosure	IP68 hermetically sealed. Hard anodized aluminium with mount options
Temperature / Humidity	-20° to 55°C ambient (Operating) / 0% - 100% RH (sealed)

ANPR ENGINE FUNCTIONALITY

4G router options	FDD / TDD 4G DC-HSPA+/HSPA+/HSPA/WCDMA/UMTS 3G, IPSec, PPTP/L2TP client, GRE/IPIP, IP packet/Domain/MAC Jitter, NAT, DMZ- Built-in watch dog, Multi-link detected on Ultra security, VPN: PPTP, L2TP, GPE, IPsec, High Reliability: Hardware link self-recovery
-------------------	---

SERVICE

Customer Service	Friendly, helpful service for product ordering and repair returns
Technical Support	Comprehensive pre and post-sale technical support for full life of the product
Warranty	12 month warranty, extended warranties and factory repair/replacement programmes available
Long Term Supply	Complete support for the life of the product
Quality Management	MAV operate a quality management system complying with ISO 9001:2000
Training	Comprehensive product training programmes for customers