

IQ:250X

ALL-IN-ONE ANPR HD ZOOM CAMERA WITH INTEGRAL ANPR RECOGNITION

MAV

ANPR TECHNOLOGY FOR
INTELLIGENT TRAFFIC SOLUTIONS

Dual All-in-one HD Zoom Camera

Incorporating HD image quality, motorized zoom, high speed ANPR recognition and maxIRange™ pulsed IR lighting in one efficient unit, the IQ:250X range sets new standards for intelligent ANPR cameras.



HD Video

Up to 8m lane width capability from digital video for maximum quality



Range

6M to 40M options for wide or Narrow IR



Integrated ANPR Engine

To provide high accuracy reads with meta data



Easy Installation

Full setup using web browser with live video



JSON Web Services

Simple integration into applications using open interface



Stand-alone

With optional sunshields and brackets for quick installation



Zoom Cameras

10 x Optical controllable truEZOOM™ for the perfect field of view



Weather Proof

Fully hermetically sealed to IP68



Powerful Pulsed IR

maxIRange™ for true day/night number plate recognition



Offline Data Management

Store and forward for offline data transfer (Optional)

IQ:250X

ALL-IN-ONE ANPR HD ZOOM CAMERA WITH INTEGRAL ANPR RECOGNITION

Recognition for up to 12m
lane width



Dual All-in-one HD Zoom Camera

The IQ:250X provides recognition up to 8m lane width for detection of plates and is simple to set up with truEZoom™ for perfect field of view at distances from 6m up to 40m. Improved low light image. Setup is performed using the camera's API or from any browser using the IQX range's web setup with live video feed.

By performing the ANPR recognition within the camera network traffic is massively reduced. Real time recognition is performed on raw high definition images at full frame rate and will work for all traffic speeds from high speed highway gantry systems to access control.

The IQX range incorporates high grade processing within the unit to give industry leading ANPR accuracy. Extensive metadata is provided for each plate read to offer application developers everything needed to determine plate characteristics, direction of travel and provide cropped overview and plate patch images. All this is available from the internal server using open standard JSON web services.

The Internal data management of the IQX range enables store and forward whilst offline, ensuring no data is lost. The IQ:250X offers store and forward buffering to provide up to one million cached reads or immediate data transfer via an API supporting JSON, FTP, UTMC1.2 and Web Services. The IQ:250X is hermetically sealed to IP68 and can be powered using PoE+ to give a single cable install.



IQ:250X

ALL-IN-ONE ANPR HD ZOOM CAMERA WITH INTEGRAL ANPR RECOGNITION

Technical Data



SPECIFICATIONS

Recognition Range	Capture of up to 12m of traffic lanes from 15m to 50m based on 850nm IR on EU retro-reflective plates
Sensor	ANPR: 1/1.8" 2064(H) x 1544(V) 16:9 global shutter, 25 fps Overview: 1/1.8" 2064(H) x 1544(V) 16:9 rolling global optional 25 fps
Motorised Lens	ANPR: motorized zoom (7.00mm-84mm), focus and iris control, Lens equivalent 51.1° to 5.0° Horizontal Field of View Overview: motorized zoom (7.00mm-84mm), focus and auto iris, Lens equivalent 51.1° to 5.0° Horizontal Field of View
IR illumination	4 pulsed LED arrays with lenses (850nm standard, White light, 740nm or 940nm optional)
Optical Filters	IR: Bandpass matched to LEDs OV: Day/Night IR Cut Filter (auto/manual)
Camera Control	Integrated web server provides full camera and illuminator setup pages and live preview from any connected browser (no plug-ins required)

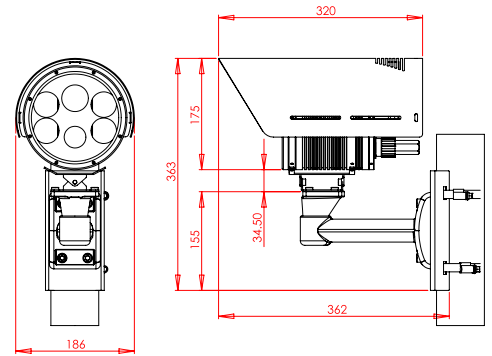

ANPR ENGINE FUNCTIONALITY

ANPR Processor	Dual Core DSP with co-processor and two channel internal parallel video input
ANPR Software / Presets	ANPR license and configuration upload via web based configuration pages for simple remote management
ANPR Engine Protocol	JSON web services provide full access to overview and plate patch images and metadata as push or pull messages for easy integration into applications (O/S independent) and via web pages
ANPR Metadata	Multiple plate tracking with IDs, full availability of plate movement/size data through field of view
ANPR Storage	Onboard storage 8GB (optionally 32GB) for up to 1 million buffered reads
ANPR Features	Image cropping options for Overview image, advanced de-skew and yaw correction, character spacing validation, country of origin matching, lane determination, direction of travel, plate tracking and geometry

PHYSICAL SPECIFICATIONS

Operating Voltage	PoE+ (803.2at type 2) or 10-15VDC suitable for battery power
Network Connections	10/100 Base-T physical
Power Consumption	Nominally 18W
Dimensions	163 x 163 x 145mm (cylindrical) excluding connectors, mount and sunshield
Weight	2.5kg excluding mount and sunshield
Enclosure	IP68 hermetically sealed. Hard anodized aluminium with mount options
Temperature / Humidity	-30°C to 55°C operating with relative humidity 0%RH to 100%RH (hermetically sealed)

SERVICE

Customer Service	Friendly, helpful service for product ordering and repair returns
Technical Support	Comprehensive pre and post-sale technical support for full life of the product
Warranty	12 month warranty, extended warranties and factory repair/replacement programmes available
Long Term Supply	Complete support for the life of the product
Training	Comprehensive product training programmes for customers